



# 承认书

## APPROVAL SHEET

编号 No.	
日期 Date	

客户 Customer	
----------------	--

品名 Product	<b>Thermal cut-out</b>
系列 Series	ATM-01

料号 Part No.	规格描述 Specification	备注 Remark
贝特电子 Betterfuse		
客户 Customer		

环保特别提示 Special instructions for environmental protection
本产品: 符合 ROHS

供应商-贝特电子 Supplier-Betterfuse	零件承认章 Approval Signet	客户 Customer	零件承认章 Approval Signet
制作 Make			
审核 Check			
确认 Approval			

联络 Contact			
业务 Sales	电话 Telephone	手机 Cellphone	邮箱 E-mail
零件承认后敬请回签一份给我司留存, 或将承认后的封面传真 (0769-8352 1857) 至我司, 谢谢!			

Document Record						
NO.	Date	Modified Content	Page	Edition	Prepared/modified by	Checked by
1						
2						
3						
4						
5						
6						
7						
8						
9						
10						

## TABLE OF CONTENTS

<b>1. COPE AND DESCRIPTION .....</b>	<b>2</b>
<b>2. GENERAL INFORMATION.....</b>	<b>2</b>
<b>3. AGENCY APPROVALS.....</b>	<b>2</b>
<b>4. PRODUCT MODEL.....</b>	<b>3</b>
<b>5. STRUCTURE .....</b>	<b>3</b>
<b>6. ELECTRICAL CHARACTERISTICS.....</b>	<b>4</b>
<b>7. TEMPERATURE CHARACTERISTIC .....</b>	<b>4</b>
<b>8. ORDERING INFORMATION .....</b>	<b>4</b>
<b>9. PACKING INFORMATION.....</b>	<b>5</b>
<b>10. APPENDIX.....</b>	<b>6</b>

## 1. SCOPE AND DESCRIPTION

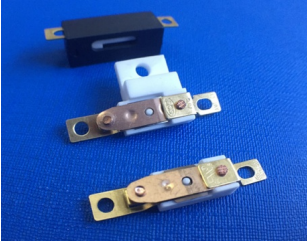

The product for the ATM series thermostat. Mainly used for overheating or over temperature protection of electrical products.

ATM series thermal cut-out, widely used, mainly used in the heater, hair dryer, slow cooker, lamps and other related temperature appliances on the overheating or over temperature protection.

## 2. GENERAL INFORMATION

### General Description

Function: ATM thermal cut-out is through the bimetal discs the change of temperature jump off action, and then cut off the circuit. The circuit of overheat or over temperature protection..

Construction: It is mainly composed of three major components: bimetal strip action mechanism, ceramic seat and terminals



### Characteristics:

1. The bimetal discs is not electrified, so its operating temperature is not affected by the current;
2. It is sensitive to temperature, moves quickly, and has flexible installation form, which is widely used in temperature related appliances as over temperature protection or overheat protection

### Detailed Features:

- Operating Temperature: 60°C~150°C
- Tolerance:  $\pm 5^{\circ}\text{C}$
- Temperature difference between operated and resetable temperature : 15°C~50°C
- Endurance: 100,000 cycles (Automatic reset)
- Resistance between contacts <50m $\Omega$
- Hi-pot test: 1500VAC 0.5mA 1min
- Insulation resistance: >5M $\Omega$

## 3. AGENCY APPROVALS

Approval	Certification No.	Rate Voltage / Ampere
	E468091	125VAC 50/60Hz 16A 100,000 cycles(ATM-01); 10,000 cycles(ATM-01P)
	CQC14002118788	250VAC 10A/16A 10,000 cycles
	R50297266	250VAC 50/60Hz 10A/16A 10,000 cycles
<b>CB</b>	CN31936-A1/M1	250VAC 10A/16A 10,000 cycles

## 4. PRODUCT MODEL

Model: ATM-01 ; ATM-01P

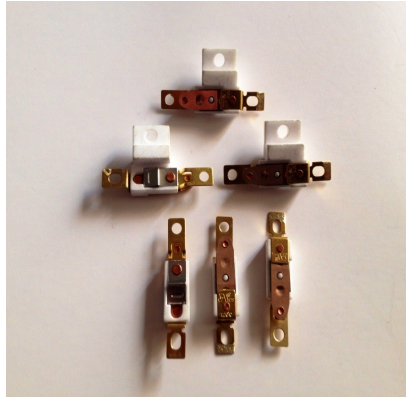

## 5. STRUCTURE

### ATM-01

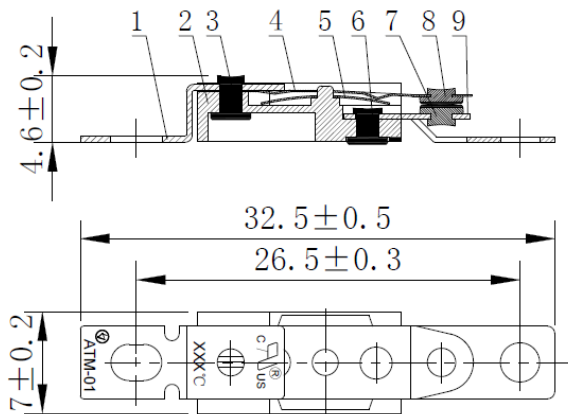

- 1 Terminal
- 2 Ceramic seat
- 3 Long rivet
- 4 Movable arm
- 5 Bimetal discs
- 6 Short rivet
- 7 Static contact
- 8 Movable contact
- 9 Static plate

### ATM-01P

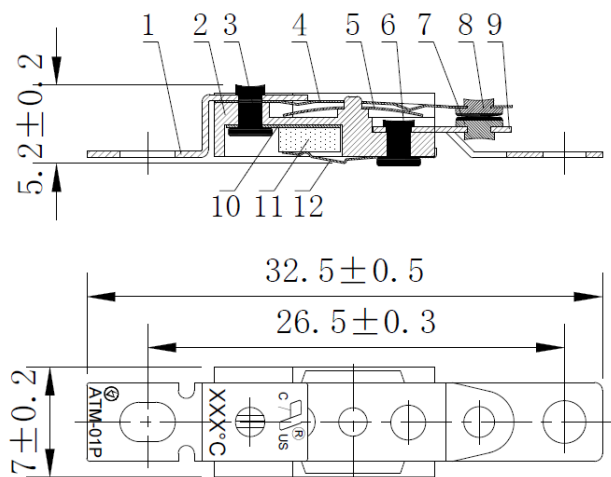

- 1 Terminal
- 2 Ceramic seat
- 3 Long rivet
- 4 Movable arm
- 5 Bimetal discs
- 6 Short rivet
- 7 Static contact
- 8 Movable contact
- 9 Static plate
- 10 Shim
- 11 PTC
- 12 Shrapnel

## 6. ELECTRICAL CHARACTERISTICS

Rated parameter: AC250V 16A /AC125V 16A

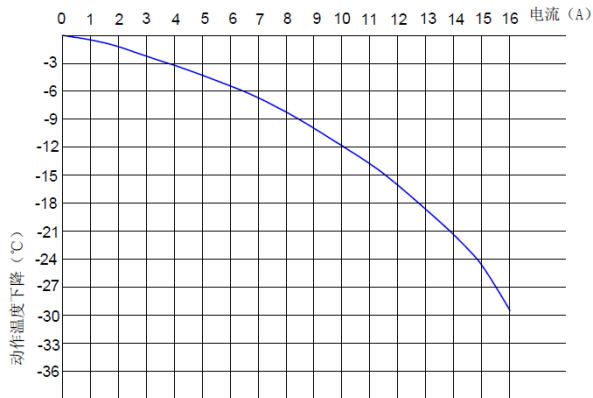

Open Temp. Drop due to Current

## 7. TEMPERATURE CHARACTERISTIC

Temperature Characteristics					
Model	Operating Temperature(°C)	Reset Temperature(°C)	Approval		
			TUV 250V	UL 125V	CQC 250V
ATM060****	60±5	45±8	•	•	•
ATM065****	65±5	48±10	•	•	•
ATM070****	70±5	50±12	•	•	•
ATM075****	75±5	53±15	•	•	•
ATM080****	80±5	55±15	•	•	•
ATM085****	85±5	60±15	•	•	•
ATM090****	90±5	60±15	•	•	•
ATM095****	95±5	65±15	•	•	•
ATM100****	100±5	70±15	•	•	•
ATM105****	105±5	75±15	•	•	•
ATM110****	110±5	75±15	•	•	•
ATM115****	115±5	80±15	•	•	•
ATM120****	120±5	85±15	•	•	•
ATM125****	125±5	85±15	•	•	•
ATM130****	130±5	90±15	•	•	•
ATM135****	135±5	95±15	•	•	•
ATM140****	140±5	100±15	•	•	•
ATM145****	145±5	100±15	•	•	•
ATM150****	150±5	105±15	•	•	•

Note: Reset Temperature only reference

## 8. ORDERING INFORMATION

The following information are necessary in order to place your order with us correctly:

Model No.	Operating Temperature	Supplementary Code	Quantity
ATM-01 or 01P			

## 9. PACKING INFORMATION

Packing details:

\* Unit:mm

**Inner Box**

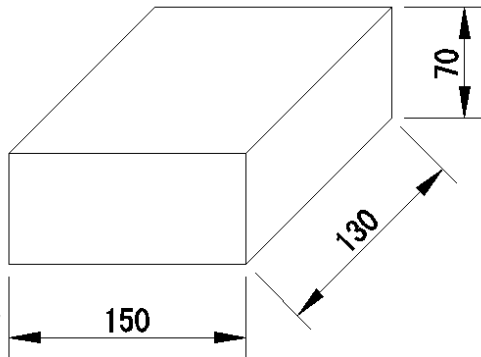

**Master Carton**

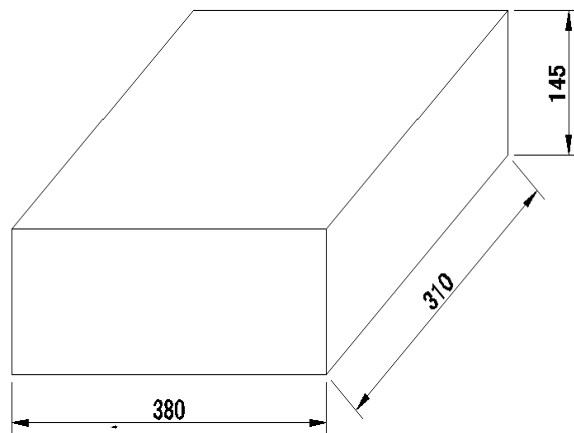

Net Weight (100pcs/tray)	1.42g	Inner box weight	1170g	Master Carton Weight	≈ 12.1KG
Qty per tray	100pcs	Qty per box	600pcs	Qty per carton	6000pcs

DongGuan Better Electronics Technology Co., Ltd.

东莞市贝特电子科技股份有限公司

Tel: +86 769-8323 8731/8323 8732 EXT:807; Fax: +86 769-8352 1857;

website: [www.betterfuse.com](http://www.betterfuse.com)

Add.: No.7, Sanhe Road, Hengkeng Administrative Zone, Liaobu Town, Dongguan City,  
Guangdong Province, P. R. C. 东莞市寮步镇横坑三和路7号

## 10. APPENDIX



ONLINE CERTIFICATIONS DIRECTORY

## XAPX2.E468091 Temperature-indicating and -Regulating Equipment - Component

If you notice a change to your XAPX2 Listing Card, click [here](#) to learn more.

[Page Bottom](#)

### Temperature-indicating and -Regulating Equipment - Component

[See General Information for Temperature-indicating and -Regulating Equipment - Component](#)

#### DONGGUAN BETTER ELECTRONICS TECHNOLOGY CO LTD

E468091

Rm 601 Of 16 Blk  
Xinzhu Yuan No 4 Xinzhu Rd  
Songshanlake Hightech Industrial Development Zone  
Dongguan, Guangdong 523808 CHINA

**Protective control, Thermal cut-out** Model(s) ATM-01

**Investigated to UL-60730-1**

**Protective control, Voltage maintained thermal cut-out** Model(s) ATM-01P

**Investigated to UL-60730-1, UL 60730-2-9**

**Protective control,** Model(s) Thermal cut-ou ATM-01 Series, Voltage maintained thermal cut-out ATM-01P Series

Model(s) KST-A, KST-B, KST-C, KST-D, KST-R

Marking: Company name and model designation.

Last Updated on 2017-05-08

[Questions?](#)

[Print this page](#)

[Terms of Use](#)

[Page Top](#)

© 2018 UL LLC

The appearance of a company's name or product in this database does not in itself assure that products so identified have been manufactured under UL's Follow-Up Service. Only those products bearing the UL Mark should be considered to be Certified and covered under UL's Follow-Up Service. Always look for the Mark on the product.

UL permits the reproduction of the material contained in the Online Certification Directory subject to the following conditions: 1. The Guide Information, Assemblies, Constructions, Designs, Systems, and/or Certifications (files) must be presented in their entirety and in a non-misleading manner, without any manipulation of the data (or drawings). 2. The statement "Reprinted from the Online Certifications Directory with permission from UL" must appear adjacent to the extracted material. In addition, the reprinted material must include a copyright notice in the following format: "© 2018 UL LLC".

#### I. Electrical (+) -

Series	Contact Description	Electrical Ratings			Opening Temp Rating, °C	Operating or Protective	Complete Declar. (i.e. 1.C.L, etc.)
		Volt. VAC,	Current, Amps	Type of Load			
ATM-01	SPST,NC	125 V ac, 50/60 Hz	16 A, 100,000 cycles	Resistive	60~150°C	protective	2.B
ATM-01P	SPST, NC	125 V ac, 50/60 Hz	16 A, 10,000 cycles	Resistive	60~150°C	protective	2.C.AK



# 产品认证证书

证书编号：CQC14002118788

## 申请人名称及地址

东莞市贝特电子科技股份有限公司  
东莞市松山湖高新技术产业开发区新竹路4号新竹苑16座办公601

## 制造商名称及地址

东莞市贝特电子科技股份有限公司  
东莞市松山湖高新技术产业开发区新竹路4号新竹苑16座办公601

## 生产企业名称及地址

东莞市贝特电子科技股份有限公司(V036003)  
东莞市寮步镇横坑三和路7号

## 产品名称和系列、规格、型号

温控器（热切断器）

ATM系列 250VAC 16A, 250VAC 10A 动作温度范围 60℃-150℃ 1.C型 10000 周期 绝缘  
支撑件为陶瓷 自动复位 污染等级 2（系列命名方式见附件）

## 产品标准和技术要求

GB/T14536.1-2008; GB/T14536.10-2008

## 认证模式

产品型式试验+初次工厂检查+获证后监督

上述产品符合 CQC11-448321-2016 认证规则的要求，特发此证。

发证日期：2019年07月26日

本证书的有效性依据发证机构的定期监督获得保持。

本证书为变更证书，证书首次颁发日期：2014年12月08日

主任：\_\_\_\_\_

陆梅



## 中国质量认证中心

中国·北京·南四环西路188号9区100070

<http://www.cqc.com.cn>

C 0151554



**Zertifikat****Certificate**

Zertifikat Nr. *Certificate No.*  
R 50297266

Blatt *Page*  
0001

Ihr Zeichen *Client Reference*

Unser Zeichen *Our Reference*  
05-RBI- 16060507 001

Ausstellungsdatum  
13.11.2014

*Date of Issue*  
(day/mo/yr)

**Genehmigungsinhaber *License Holder***

Dongguan Better Electronics  
Technology Co., Ltd.  
Room 601 of 16 Block, Xinzhu Yuan  
No 4, Xinzhu Road, Songshanlake  
Hightech Ind. Development Zone  
Dongguan City, Guangdong Province  
P.R. China

**Fertigungsstätte *Manufacturing Plant***

FOSHAN WHOLESOME ELECTRONICS  
CO., LTD.  
No. 17 Wufeng Industrial Zone  
Dasha Road, Zhangcha  
Foshan, Guangdong 528000  
P.R. China

**Prüfzeichen *Test Mark***

Type Approved  
Safety  
Regular Production  
Surveillance

www.tuv.com  
ID 2000000000

**Geprüft nach *Tested acc. to***

EN 60730-1:2000+A1+A2+A12+A13+A14+A16  
EN 60730-2-9:2010

**Zertifiziertes Produkt (Geräteidentifikation)**

*Certified Product (Product Identification)*

**Lizenzentgelte - Einheit**

*License Fee - Unit*

**Temperature Control (Thermal cut-out)**

Type Designation	: ATM-01P ATM-01	6
Trademark	: Better (logo)	
Rated Voltage	: AC 250V; 50Hz	
Rated Current	: 10A	
Operation Cycles	: 10,000 (Automatic reset)	
Operating Temperature	: 60°C - 150°C	
Action Type	: 1.C	
Degree of Protection	: IP00	
Degree of Pollution	: 2	
Rated Impulse Voltage	: 2500V	
Type of Disconnection	: Micro-interruption	
Construction	: Incorporated Control for Class I or II Equipment	

Remark : The labelling requirements acc. to EU Directive 2001/95 have to be observed for distribution within the EEA. The installation has to be carried out according to installation instruction accompanying the products.

**ANLAGE (Appendix): 1**

Dem Zertifikat liegt unsere Prüf- und Zertifizierungsordnung zugrunde und es bestätigt die Konformität des Produktes mit den oben genannten Standards und Prüfgrundlagen. Zusätzliche Anforderungen in Ländern, in denen das Produkt in Verkehr gebracht werden soll, müssen zusätzlich betrachtet werden. Die Herstellung des zertifizierten Produktes wird überwacht.  
This certificate is based on our Testing and Certification Regulation and states the conformity of the product with the standards and testing requirements as indicated above. Any additional requirements in countries where the product is going to be marketed have to be considered additionally. The manufacturing of the certified product is subject to surveillance.

**TÜV Rheinland LGA Products GmbH - Tillystraße 2 - 90431 Nürnberg**

Tel.: (+49/221)8 06 - 13 71 e-mail: cert-validity@dc.tuv.com

Fax: (+49/221)8 06 - 39 35 http://www.tuv.com/safety



G. Yin

**Zertifikat****Certificate**

Zertifikat Nr. *Certificate No.*  
R 50297266

Blatt *Page*  
0002

<i>Ihr Zeichen Client Reference</i>	<i>Unser Zeichen Our Reference</i>	<i>Ausstellungsdatum</i>	<i>Date of Issue</i> (day/mo/yr)
	05-YFC- 16060507 002	22.07.2016	

**Genehmigungsinhaber *License Holder***  
Dongguan Better Electronics  
Technology Co., Ltd.  
Room 601 of 16 Block, Xinzhuoyuan  
No 4, Xinzhu Road, Songshanlake  
Hightech Ind. Development Zone  
Dongguan City, Guangdong Province  
P.R. China

**Fertigungsstätte *Manufacturing Plant***  
Dongguan Better Electronics  
Technology Co., Ltd.  
Nanmen Village, Hengkeng  
Administrative Zone, Liaobu Town  
Dongguan, Guangdong  
P.R. China

**Prüfzeichen *Test Mark***

Type Approved  
Safety  
Regular Production  
Surveillance

www.tuv.com  
ID 2000000005

**Geprüft nach *Tested acc. to***

EN 60730-1:2000+A1+A2+A12+A13+A14+A16  
EN 60730-2-9:2010

**Zertifiziertes Produkt *(Geräteidentifikation)***  
***Certified Product (Product Identification)***

**Lizenzentgelte - Einheit**  
***License Fee - Unit***

Temperature Control (Thermal cut-out)

as page 0001

Change

Name of the factory : see above  
Address of the factory : see above

Remark : The labelling requirements acc. to EU Directive  
2001/95 have to be observed for distribution within the EEA.  
The installation has to be carried out according to  
installation instruction accompanying the products.

Dem Zertifikat liegt unsere Prüf- und Zertifizierungsordnung zugrunde und es bestätigt die Konformität  
des Produktes mit den oben genannten Standards und Prüfgrundlagen. Zusätzliche Anforderungen  
in Ländern, in denen das Produkt in Verkehr gebracht werden soll, müssen zusätzlich  
betrachtet werden. Die Herstellung des zertifizierten Produktes wird überwacht.  
This certificate is based on our Testing and Certification Regulation and states the conformity  
of the product with the standards and testing requirements as indicated above. Any additional  
requirements in countries where the product is going to be marketed have to be considered  
additionally. The manufacturing of the certified product is subject to surveillance.

**TÜV Rheinland LGA Products GmbH - Tillystraße 2 - 90431 Nürnberg**  
Tel.: (+49/221)8 06 - 13 71 e-mail: cert-va@tuv.com  
Fax: (+49/221)8 06 - 39 35 http://www.tuv.com/safety



**Zertifikat****Certificate**

Zertifikat Nr. *Certificate No.*  
R 50297266

Blatt *Page*  
0003

Ihr Zeichen <i>Client Reference</i>	Unser Zeichen <i>Our Reference</i>	Ausstellungsdatum	<i>Date of Issue</i> (day/mo/yr)
	05-YFC- 16060507 003	22.06.2017	

**Genehmigungsinhaber *License Holder***  
Dongguan Better Electronics  
Technology Co., Ltd.  
Room 601 of 16 Block, Xinzhu Yuan  
No 4, Xinzhu Road, Songshanlake  
Hightech Ind. Development Zone  
Dongguan City, Guangdong Province  
P. R. China

**Fertigungsstätte *Manufacturing Plant***  
Dongguan Better Electronics  
Technology Co., Ltd.  
Nanmen Village, Hengkeng  
Administrative Zone, Liaobu Town  
Dongguan, Guangdong  
P. R. China

**Prüfzeichen *Test Mark*****Geprüft nach *Tested acc. to***

EN 60730-1:2000+A1+A2+A12+A13+A14+A16  
EN 60730-2-9:2010

**Zertifiziertes Produkt (Geräteidentifikation)**  
***Certified Product (Product Identification)***

**Lizenzentgelte - Einheit**  
***License Fee - Unit***

Temperature Control (Thermal cut-out)

as page 0001-0002

Addition

Rated Current : 16A 2

Remark : The labelling requirements acc. to EU Directive 2001/95 have to be observed for distribution within the EEA. The installation has to be carried out according to installation instruction accompanying the products.

2

Dem Zertifikat liegt unsere Prüf- und Zertifizierungsordnung zugrunde und es bestätigt die Konformität des Produktes mit den oben genannten Standards und Prüfgrundlagen. Zusätzliche Anforderungen in Ländern, in denen das Produkt in Verkehr gebracht werden soll, müssen zusätzlich betrachtet werden. Die Herstellung des zertifizierten Produktes wird überwacht. This certificate is based on our Testing and Certification Regulation and states the conformity of the product with the standards and testing requirements as indicated above. Any additional requirements in countries where the product is going to be marketed have to be considered additionally. The manufacturing of the certified product is subject to surveillance.

**TÜV Rheinland LGA Products GmbH - Tillystraße 2 - 90431 Nürnberg**

Tel.: (+49/221)8 06 - 13 71 e-mail: cert-validity@de.tuv.com  
Fax: (+49/221)8 06 - 39 35 http://www.tuv.com/safety



**Zertifikat****Certificate**

Zertifikat Nr. *Certificate No.*  
R 50297266

Blatt Page  
0004

Ihr Zeichen *Client Reference*

Unser Zeichen *Our Reference*  
05-YFC- 16060507 004

Ausstellungsdatum  
09.11.2017

*Date of Issue*  
(day/mo/yr)

**Genehmigungsinhaber *License Holder***  
Dongguan Better Electronics  
Technology Co., Ltd.  
Room 601 of 16 Block, Xinzhu Yuan  
No 4, Xinzhu Road, Songshanlake  
Hightech Ind. Development Zone  
Dongguan City, Guangdong Province  
P. R. China

**Fertigungsstätte *Manufacturing Plant***  
Dongguan Better Electronics  
Technology Co., Ltd.  
Nanmen Village, Hengkeng  
Administrative Zone, Liaobu Town  
Dongguan, Guangdong  
P. R. China

**Prüfzeichen *Test Mark*****Geprüft nach *Tested acc. to***

EN 60730-1:2000+A1+A2+A12+A13+A14+A16  
EN 60730-2-9:2010

**Zertifiziertes Produkt (Geräteidentifikation)**  
*Certified Product (Product Identification)*

**Lizenzentgelte - Einheit**  
*License Fee - Unit*

Temperature Control (Thermal cut-out)

as pages 0001-0003

Change

Rated Voltage : AC 250V; 50Hz/60Hz

Remark : The labelling requirements acc. to EU Directive  
2001/95 have to be observed for distribution within the EEA.  
The installation has to be carried out according to  
installation instruction accompanying the products.

*Dem Zertifikat liegt unsere Prüf- und Zertifizierungsordnung zugrunde und es bestätigt die Konformität des Produktes mit den oben genannten Standards und Prüfgrundlagen. Zusätzliche Anforderungen in Ländern, in denen das Produkt in Verkehr gebracht werden soll, müssen zusätzlich betrachtet werden. Die Herstellung des zertifizierten Produktes wird überwacht.  
This certificate is based on our Testing and Certification Regulation and states the conformity of the product with the standards and testing requirements as indicated above. Any additional requirements in countries where the product is going to be marketed have to be considered additionally. The manufacturing of the certified product is subject to surveillance.*

**TÜV Rheinland LGA Products GmbH - Tillystraße 2 - 90431 Nürnberg**  
Tel.: (+49/221)8 06 - 13 71 e-mail: cert-validity@de.tuv.com  
Fax: (+49/221)8 06 - 39 35 <http://www.tuv.com/safety>



# Zertifikat *Certificate*



**Zertifikat Nr. Certificate No.**  
R 50297266

**Blatt Page**  
0005

<b>Ihr Zeichen Client Reference</b>	<b>Unser Zeichen Our Reference</b>	<b>Ausstellungsdatum</b>	<b>Date of Issue</b> (day/mo/yr)
	05-RW- 16060507 005	30.07.2019	

## **Genehmigungsinhaber License Holder**

Dongguan Better Electronics  
Technology Co., Ltd.  
Room 601 of 16 Block, Xinzhuoyuan  
No 4, Xinzhu Road, Songshanlake  
Hightech Ind. Development Zone  
Dongguan City, Guangdong Province  
P. R. China

## **Fertigungsstätte Manufacturing Plant**

Dongguan Better Electronics  
Technology Co., Ltd. ,  
Second Branch Factory  
No.7, Sanhe Road, Hengkeng  
Administrative Zone, Liaobu Town,  
Dongguan City, Guangdong Province  
P. R. China

## **Prüfzeichen Test Mark**



Type Approved  
Safety  
Regular Production  
Surveillance

www.tuv.com  
ID 2000000000

## **Geprüft nach Tested acc. to**

EN 60730-1:2000+A1+A2+A12+A13+A14+A16  
EN 60730-2-9:2010

**Zertifiziertes Produkt (Geräteidentifikation)**  
**Certified Product (Product Identification)**

**Lizenzentgelte - Einheit**  
**License Fee - Unit**

Temperature Control (Thermal cut-out)

as pages 0001-0004

Change

Address and name of factory : See above

Remark : The labelling requirements acc. to EU Directive  
2001/95 have to be observed for distribution within the EEA.  
The installation has to be carried out according to  
installation instruction accompanying the products.

*Dem Zertifikat liegt unsere Prüf- und Zertifizierungsordnung zugrunde und es bestätigt die Konformität des Produktes mit den oben genannten Standards und Prüfgrundlagen. Zusätzliche Anforderungen in Ländern, in denen das Produkt in Verkehr gebracht werden soll, müssen zusätzlich betrachtet werden. Die Herstellung des zertifizierten Produktes wird überwacht.  
This certificate is based on our Testing and Certification Regulation and states the conformity of the product with the standards and testing requirements as indicated above. Any additional requirements in countries where the product is going to be marketed have to be considered additionally. The manufacturing of the certified product is subject to surveillance.*

**TÜV Rheinland LGA Products GmbH - Tillystraße 2 - 90431 Nürnberg**  
Tel. (+49/221)8 06 - 13 71 e-mail: cert-validity@de.tuv.com  
Fax: (+49/221)8 06 - 39 35 <http://www.tuv.com/safety>



# Zertifikat      Certificate



Zertifikat Nr. Certificate No.  
R 50297266

Blatt Page  
0006

Ihr Zeichen Client Reference	Unser Zeichen Our Reference	Ausstellungsdatum Date of Issue (day/mo/yr)
	05-RW- 16060507 006	04.11.2020

## Genehmigungsinhaber License Holder

Dongguan Better Electronics Technology Co., Ltd.  
Room 601 of 16 Block, Xinzhu Yuan No 4, Xinzhu Road, Songshan Lake Hightech Ind. Development Zone 523808 Dongguan City Guangdong P.R. China

## Fertigungsstätte Manufacturing Plant

Dongguan Better Electronics Technology Co., Ltd. , Second Branch Factory No.7, Sanhe Road, Hengkeng Administrative Zone, Liaobu Town, Dongguan City Guangdong P.R. China

## Prüfzeichen Test Mark



Type Approved  
Safety  
Regular Production  
Surveillance

www.tuv.com  
ID 2000000000

## Geprüft nach Tested acc. to

EN 60730-1:2016+A1  
EN IEC 60730-2-9:2019+A1

Zertifiziertes Produkt (Geräteidentifikation)  
Certified Product (Product Identification)

Lizenzentgelte - Einheit  
License Fee - Unit

Temperature Control (Thermal cut-out)

as pages 0001-0005

Change

Test Requirement: See above

Type Designation:

- 1) ATM-01P (Voltage maintained thermal cut-out)
- 2) ATM-01 (Thermal cut-out)

Action Type :

- 1) 1.C.AK (Automatic reset upon the loss of voltage)
- 2) 1.C (Automatic reset)

Remark : The labelling requirements acc. to EU Directive 2001/95 have to be observed for distribution within the EEA. The installation has to be carried out according to installation instruction accompanying the products.

*Dem Zertifikat liegt unsere Prüf- und Zertifizierungsordnung zugrunde und es bestätigt die Konformität des Produktes mit den oben genannten Standards und Prüfgrundlagen. Zusätzliche Anforderungen in Ländern, in denen das Produkt in Verkehr gebracht werden soll, müssen zusätzlich betrachtet werden. Die Herstellung des zertifizierten Produktes wird überwacht.  
This certificate is based on our Testing and Certification Regulation and states the conformity of the product with the standards and testing requirements as indicated above. Any additional requirements in countries where the product is going to be marketed have to be considered additionally. The manufacturing of the certified product is subject to surveillance.*

**TÜV Rheinland LGA Products GmbH - Tillystraße 2 - 90431 Nürnberg**  
Tel.: (+49/221)8 06 - 13 71 e-mail: cert-validity@de.tuv.com  
Fax: (+49/221)8 06 - 39 35 http://www.tuv.com/safety



	Ref. Certif. No.
	CN31936-A1/M1

IEC SYSTEM FOR MUTUAL RECOGNITION OF TEST  
CERTIFICATES FOR ELECTRICAL EQUIPMENT (IECEE)  
CB SCHEME

SYSTEME CEI D'ACCEPTATION MUTUELLE DE  
CERTIFICATS D'ESSAIS DES EQUIPEMENTS  
ELECTRIQUES (IECEE) METHODE OC

## CB TEST CERTIFICATE

Product  
Produit

Thermostat (Thermal cut-out)

Name and address of the applicant  
Nom et adresse du demandeur

Dongguan Better Electronics Technology Co., Ltd.  
Room 601 of 16 Block, Xinzhu Yuan, No. 4 Xinzhu Road,  
Songshanlake Hightech Industrial Development Zone, Dongguan  
City

Name and address of the manufacturer  
Nom et adresse du fabricant

Dongguan Better Electronics Technology Co., Ltd.  
Room 601 of 16 Block, Xinzhu Yuan, No. 4 Xinzhu Road,  
Songshanlake Hightech Industrial Development Zone, Dongguan  
City

Name and address of the factory  
Nom et adresse de l'usine

Dongguan Better Electronics Technology Co., Ltd.  
NanMen Village, HengKeng Administrative Zone LiaoBu Town,  
Dongguan City, Guangdong Province, China.

Note: When more than one factory, please report on page 2  
Note: Lorsqu'il y a plus d'une usine, veuillez utiliser la 2<sup>ème</sup> page

Ratings and principal characteristics  
Valeurs nominales et caractéristiques principales

250VAC 16A/250VAC 10A 60-150°C Type 1.C 10000  
cycles

Trademark (if any)  
Marque de fabrique (si elle existe)

ATM series

Model / Type Ref.  
Ref. De type

Additional information (if necessary may also be reported  
on page 2)  
Les informations complémentaires (si nécessaire, peuvent être  
indiqués sur la 2<sup>ème</sup> page)

PUBLICATION

EDITION

A sample of the product was tested and found  
to be in conformity with  
Un échantillon de ce produit a été essayé et a été  
considéré conforme à la

IEC60730-2-9: 2008 (Third Edition) and Am.1:2011 in  
conjunction with IEC 60730-1:2010 (Fourth Edition)

As shown in the Test Report Ref. No. which forms part  
of this Certificate  
Comme indiqué dans le Rapport d'essais numéro de  
référence qui constitue partie de ce Certificat

CVC2014-0593-M1

This CB Test Certificate is issued by the National Certification Body  
Ce Certificat d'essai OC est établi par l'Organisme National de Certification



CHINA QUALITY CERTIFICATION CENTRE

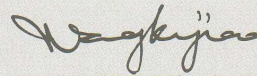

Date: 2017-05-18

Signature:

Wang Kejiao

Issued 2003-05  
China Quality Certification Centre  
Section 9, No. 188, Nansihuan Xilu, Beijing 100070 P.R. China

Tel: +86-10-83886666  
Fax: +86-10-83886282

website  
www.cqc.com.cn

CB 0039108